

Ideal Roofing offers the ultimate protection against water leakage with the "Pocket Rib".

The Pocket Rib provides superior strength with its four 3/4" (19mm) high ribs and eliminates any chance of water infiltration with a unique over-lap system that combines the safety of double ribs, with an anti-siphon pocket.

Designed as a roofing sheet for long or low rafters, (as low as 2/12 pitch), the Pocket Rib is suitable on residential, agricultural and light commercial or industrial buildings. This product is roll-formed in panels covering 29" (737mm) in width and custom-cut in lengths up to 40 (12.2m) feet for fast and easy installation.

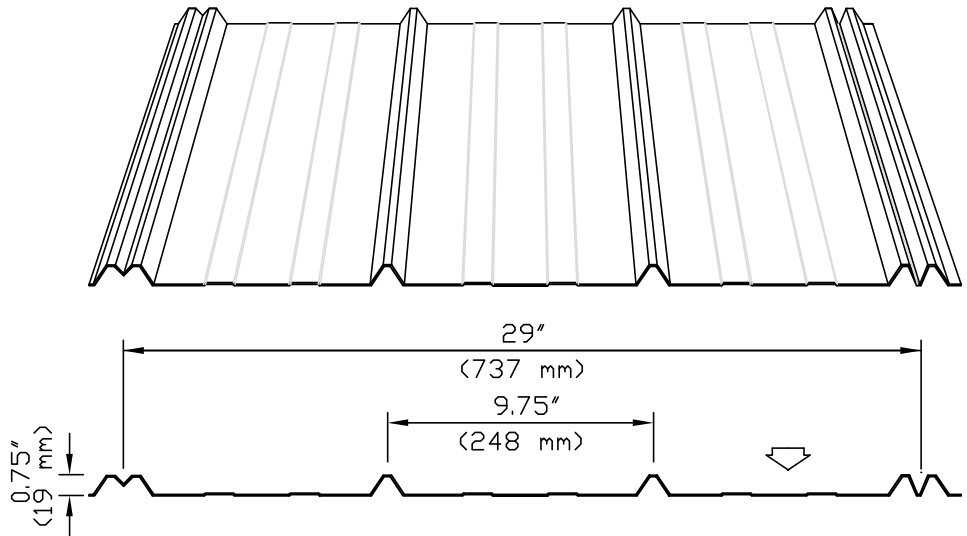

Pocket Rib

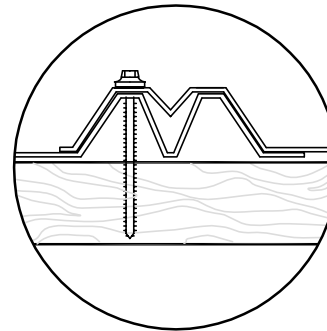

### AVAILABLE MATERIALS

#### Mill finish Galvanized Steel

- (ASTM-A653 SS grade 33, Z275 (G-90));
- gauges: 30 (.015"/0.38mm thick),
- 28 (.018"/0.45mm thick),
- 26 (.021"/0.54mm thick),
- 24 (.026"/0.66mm thick).

#### Mill finish Galvalume Plus Steel

- (ASTM-A792 SS grade 33, AZ165);
- gauges: 30 (.015"/0.38mm thick),
- 28 (.018"/0.45mm thick),
- 26 (.021"/0.54mm thick).

#### Pre-painted Galvanized Steel

- (ASTM-A653 SS grade 33, Z275 (G-90));
- Perspectra **PLUS**™ Series / Weather XL™;
- see colour chart;
- gauges: 30 (.015"/0.38mm thick),
- 28 (.018"/0.45mm thick),
- 26 (.021"/0.54mm thick),
- 24 (.026"/0.66mm thick).

#### Aluminum Plain and Diamond Embossed

- gauge: 25 (.0175"/0.44mm thick)

#### Aluminum Pre-painted White

- gauge: 23 (.023"/0.58mm thick)

Minimum Yield Stress	Fy = 33,000.00 P.S.I. (228 Mpa)
Maximum Working Stress Fb	= 20,625.00 P.S.I. (144 Mpa)
Young's Modulus	(E) = 29,500,000.00 P.S.I. (203 Mpa)

UNIFORMLY DISTRIBUTED LOADS (psf/ Kpa)					
Span Condition	Span in (mm)	30 gauge	28 gauge	26 gauge	24 gauge
		(.015" / 0.38mm)	(.018" / 0.45mm)	(.021" / 0.54 mm)	(.026" / 0.66 mm)
		D	D	D	D
	12 (305)	241 (11.77)	335 (16.35)	455 (22.21)	694 (33.88)
	15 (381)	143 (6.98)	198 (9.67)	259 (12.64)	416 (20.31)
<b>T</b>	18 (457)	97 (4.74)	135 (6.59)	173 (8.45)	270 (13.18)
<b>R</b>	21 (533)	74 (3.61)	97 (4.74)	118 (5.76)	208 (10.15)
<b>I</b>	24 (610)	54 (2.64)	70 (3.42)	90 (4.39)	171 (8.35)
<b>P</b>	30 (762)	32 (1.56)	40 (1.95)	54 (2.64)	113 (5.52)
<b>L</b>	36 (914)	18 (0.88)	27 (1.32)	34 (1.66)	77 (3.76)
<b>E</b>	42 (1067)	16 (0.78)	22 (1.07)	27 (1.32)	54 (2.64)
	48 (1220)	15 (0.73)	20 (0.98)	26 (1.27)	49 (2.20)

D = Load capacity based on deflection L/180